



## SmartFAST and SmartFASTMINI

Vertical Laminar  
Airflow Cabinets



PROTECTION, SAFETY, RELIABILITY.  
AND MORE.

# SmartFast

Vertical Laminar Airflow Cabinet

## BEYOND MINIMUM SAFETY REQUIREMENTS

The **SmartFAST cabinet** is a compact Class ISO 3 vertical laminar flow cabinet which guarantees excellent decontaminated working area and particle-free conditions, especially designed for molecular biology applications.

The SmartFAST cabinet is fitted with a H14 HEPA/ULPA filter (air cleanliness in Class ISO 3, according to ISO 14644-1) with efficiency better than 99,995% MPPS (EN-1822).

SmartFAST cabinet can be easily set to operate in two alternative modes: it can work in "positive pressure" and under "negative pressure".

## APPLICATIONS

**Faster SmartFAST cabinet** is "ISO Class 3" vertical laminar flow cabinet which guarantees excellent decontaminated working area and particle-free conditions.

The cabinet is suitable to handle **nucleic acids used in thermocycling, DNA amplifications, PCR applications, non-pathogenic microbiological and cell cultures applications.**





### CONSTRUCTION

Epoxy cold rolled steel painted with antimicrobial ALESTA® coating, AISI 304L work and back surface with rounded edge corners.



### SAFETY WINDOW

The frontal glass is hinged and can be folded upwards for cleaning and transfer material purposes.



### UTILITIES

SmartFAST cabinet is supplied, as standard, with one electrical socket and DEHS test port.

SmartFAST cabinet is also supplied as standard with four side holes and caps for optional taps installation.



### UV STERILIZING LAMP

Optional UV sterilizing lamp with manual on/off switch.

UV timer is available installing the "Digital UV Timer and Hour Counter" option. Full programmable UV light including timer and delayed start-up, is available installing the option "Automatic regulator with Digital Display and Anemometer".



### KIT BIOHAZARD

The cabinet can be optionally outfitted with a special Biohazard Kit which enables the unit to work with pathogens as defined in the appropriate International Standards.

The cabinet can be transformed in a real biohazard unit in accordance with the airflow performances required by EN-12469:2000.



# SmartFast

Vertical Laminar Airflow Cabinet

## SmartFAST KEYBOARD

Membrane keyboard with LCD screen and touch sensitive buttons for: main on/off switch, light, electrical outlet, half speed reduction and UV light (if installed). Airflow speed visualization is enabled installing the option "Automatic regulator with Digital Display and Anemometer".



## OPERATIONAL PRINCIPLES

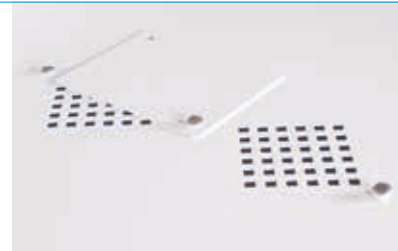

Detail of the closing panel on the top of the cabinet to switch from positive to negative pressure.

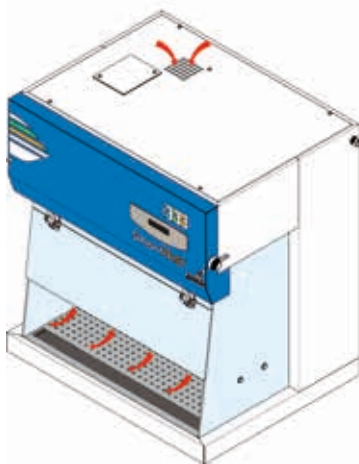

Closing panel in position A - Positive pressure

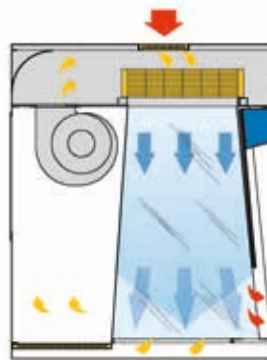

### POSITIVE PRESSURE

The air stream flowing down in laminar airflow pattern from the H14 HEPA/ULPA filter passes through the perforated work surface. An air intake from the top side creates a slight positive pressure in the cabinet, which causes some of the air to be exhausted from the front aperture.

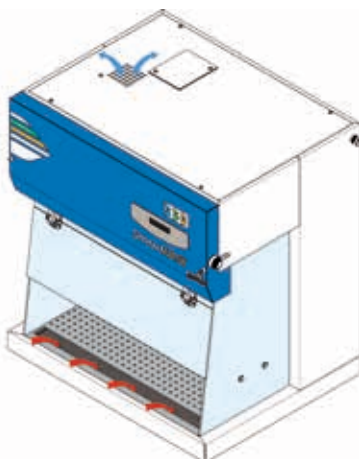

Closing panel in position B - Negative pressure

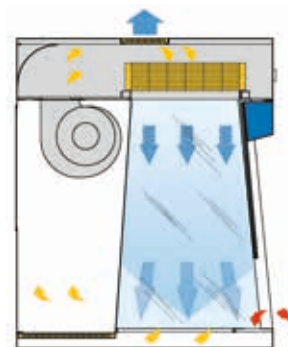

### NEGATIVE PRESSURE

The ambient air is drawn in through the slots of the stainless-steel base at the front opening and it then passes under the work surface, from where it is drawn up and channeled after filtration through a H14 HEPA/ULPA filter in laminar air flow condition (about 90%) and exhausted outside (about 10%) from the upper side of the cabinet.



# SmartFAST MINI

Vertical Laminar Airflow Cabinet

## BEYOND MINIMUM SAFETY REQUIREMENTS

**SmartFAST MINI cabinet** is a small work-station suitable for handling products that need to be protected against non-pathogenic airborne contamination.

The compact, portable cabinet can be easily moved and positioned on bench tops of a variety of different laboratories. It is suitable for various requirements such as: not pathogenic microbiology and cell cultures manipulation.

The SmartFAST MINI cabinet is fitted with a H14 HEPA/ULPA filter (air cleanless in Class ISO 3, according to ISO 14644-1) with an efficiency better than 99,995% MPPS (EN-1822) as well as a synthetic fibre pre-filter with minimum efficiency of 80%-90% ASHRAE.



## OPERATIONAL PRINCIPLES

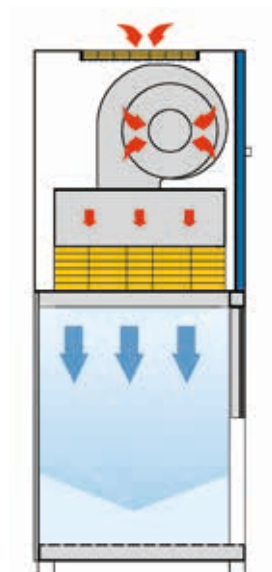

The ambient air is drawn in through the pre-filter fitted in the upper side of the cabinet and it then filtered through the HEPA filter into the work-area in laminar air flow conditions. The same volume of air is exhausted outside from the frontal aperture and under the work surface.

## TECHNICAL SPECIFICATIONS

Description	Unit	SmartFAST	SmartFAST MINI
Overall Dimensions (WxDxH)	mm	830x652x925	642x340x830
Useful Dimensions (WxDxH)	mm	732x380x580	580x315x376
Light	Lux	600	n/a
Noise Level	dB (A)	53	53
Code number		F00012100000	F00012200000
Power	Kw	0.20	0.11
Supply	V/Hz	220-230/50	220-230/50
Weight	kg	75	50

## OPTIONS AND ACCESSORIES FOR SmartFAST CABINET ONLY

FX0012146000	UV lamp for SmartFAST with aluminium front closure
FX0012146100	Stainless steel front closure for SmartFAST
FX0012149500	Service connection for electrical power, factory fitted
FX0011247100	Service connection for vacuum
FX0011247200	Service connection for compressed air
FX0011247300	Service connection for nitrogen
FX0012150000	Digital UV Timer and Hour Counter
FX0012149800	Automatic Regulator with Digital Display and Anemometer
FX0012140200	Exhaust HEPA Filter with relevant housing (for negative pressure unit)
FX0012140300	Exhaust A/C Filter with relevant housing (for negative pressure unit)
FX0012149900	Differential pressure gauge, factory fitted (on the rear panel)
FX0012149700	DOP/DEHS 100% port
FX0012145000	Epoxy powder painted modular stand for SmartFAST
FX0012145100	Epoxy powder painted modular stand for SmartFAST with castors
FX0000064810	3-Drawers unit on pivoting Castors and removable epoxy powder painted vessels Kit Biohazard



Striving everyday to improve our environmental performance, Faster developed environmental procedures are founded on three guiding principles:

- Protect the Environment for present and future generations: manufacturing low energy consumption equipments
- Reduce risks and improve efficiencies
- Introduce improved technology and processes